

CONOFLOW CUSHION LOADING REGULATOR GH04 Series

The model GH04 Cushion Loading Regulator is a compact unit designed for industrial and commercial services requiring a constant, regulated air pressure. Primarily used as a cushion loading device for Conoflow Piston Actuators, this unit's design and high exhaust capabilities lend itself to many other application requirements.

Constructed of all aluminum, this lightweight unit offers versatility in line mounting and gauge mounting with dual input and output 1/4" NPT connections. It is available with a 0-60 PSI (0-414 kPa) regulated pressure range and Buna "N" elastomers. The controlling ball valve is Viton.

Backed by Conoflow's years of experience as a leading producer of precision built instruments.

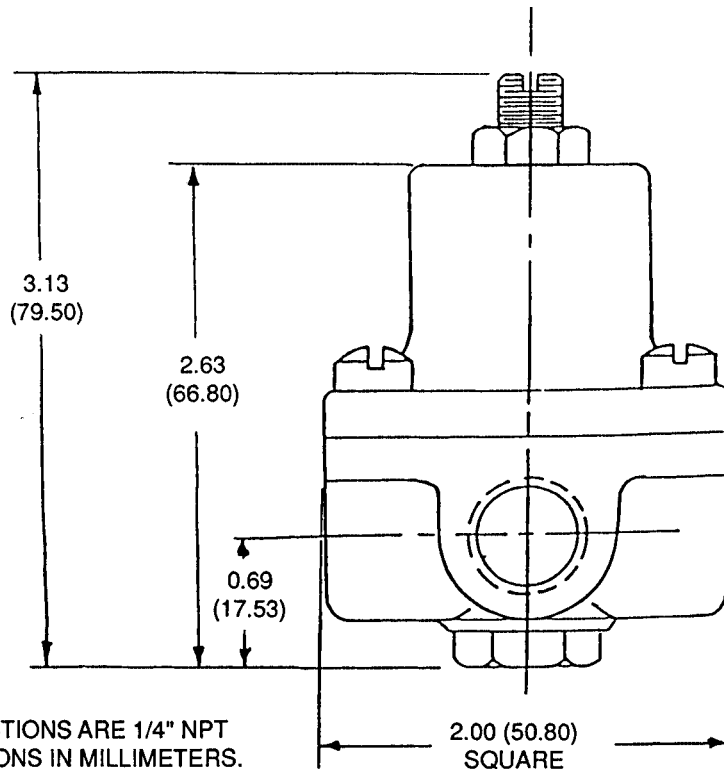

NOTE: 1. ALL CONNECTIONS ARE 1/4" NPT
2. () DIMENSIONS IN MILLIMETERS.

PRINCIPLE OF OPERATION

Turning the adjusting screw changes the force exerted by the range spring on the diaphragm assembly. In equilibrium, the force exerted by the range spring is balanced by the force from the output pressure acting underneath the diaphragm assembly.

An unbalance between the output pressure and the set pressure causes a corresponding reaction in the diaphragm and nozzle assemblies. If the output pressure rises above the set pressure, the diaphragm seat is lifted from the ball, venting the excess pressure to atmosphere until equilibrium is reached. If the output pressure drops below the set pressure, the unbalanced force from the range spring acts through the diaphragm assembly unseating the nozzle ball. This allows supply pressure to flow to the downstream port increasing the output pressure. The output pressure increases until it balances the force on the diaphragm assembly by the range spring. At equilibrium, the ball assumes a position which supplies the required flow while maintaining the output pressure at the set pressure.

A no bleed/no relief diaphragm assembly is used to prevent the process media from exhausting to atmosphere. This option is typically used with liquids and toxic gases. The principle of operation is the same as above except that excess output pressure is not vented to atmosphere. Instead, as the diaphragm seat lifts off the ball and the ball is forced against its seat by the nozzle spring the excess pressure is relieved downstream.

MATERIALS OF CONSTRUCTION

Body: Aluminum
Bonnet: Aluminum
Diaphragm Assembly: Buna "N"
Ball Valve: Viton
Range Spring: Steel Cadmium Plated

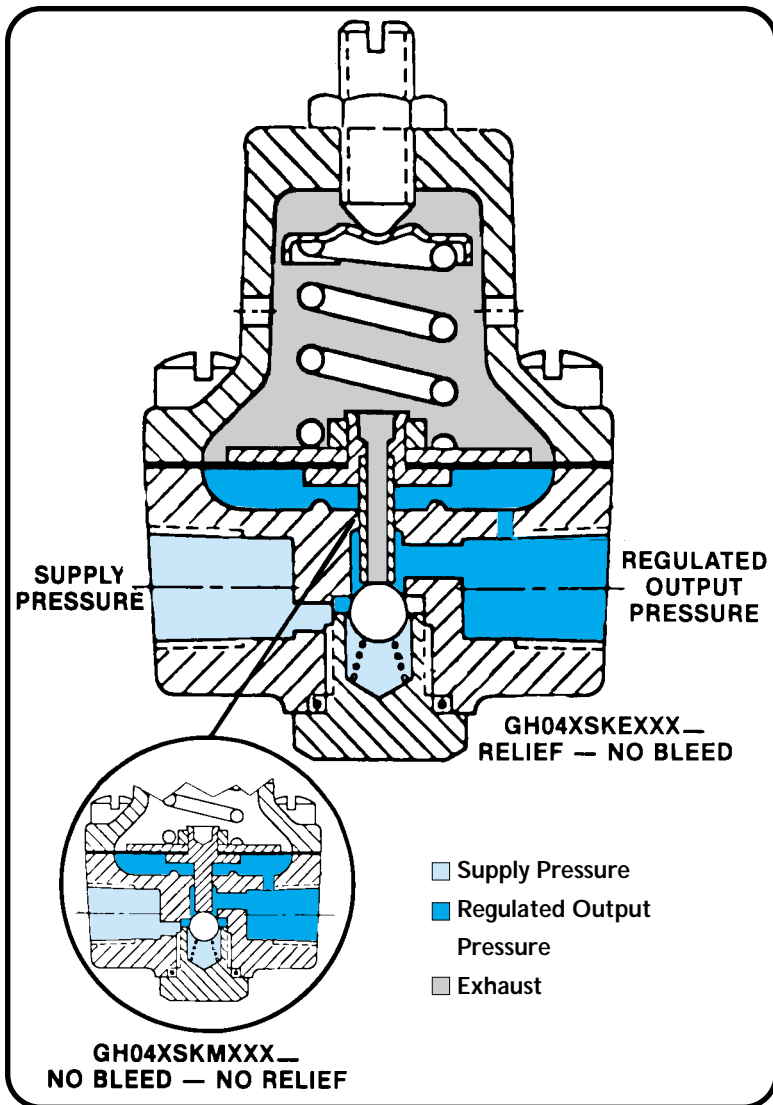

SPECIFICATIONS

OPERATING CHARACTERISTICS

Maximum Supply Pressure: 300 PSI (2068 kPa)
Regulated Output Pressure Ranges: 0-60 PSI (0-414 kPa)
Connections: 1/4" NP{T (Four)
Flow Capacity: 2 SCFM (0.57 m³/min)
 [with 100 PSI (690 kPa) Supply Pressure]
Exhaust Capacity: 6 SCFM (0.170 m³/min)
Sensitivity: 0.1 PSI (0.689 kPa)
Supply Pressure Effect: 1.6 PSI (11.03 kPa) for 25 PSI (172 kPa)
 change in supply pressure
Ambient Temperature Range: -20°F to +150°F (-29°C to +66°C)
Approximate Shipping Weight: 1 lb. (25.4 Kg)

CONTROL ENGINEERING DATA

GH04 = Cushion Loading Regulator
 X = Absence of Specification
 S = Plain Bonnet - No Thread
 K = Knob (Screwdriver slot type)
 E = w/Relief - No Bleed
 M = No Bleed - No Relief
 X = Absence of Specification
 F = 0-60 PSI (0-414 kPa) Range